

VERO300 - PL300 Beam Spot Wash 3in1



SPECIFICATION

OPTICS

- Light Source :300W White LED Module
- Lifetime: 50000 Hours
- Color temperature:7000K

MOVEMENT

- Pan movement:540°(16 bit)
- Tilt movement :270°(16 bit)
- Automatic reset function

COLORS

- 1+11colors, Bi-directional rainbow effect •Linear CMY+CTO

GOBOS

- Fixed gobo wheel: 14 gobos + open
- Rotating gobo wheel: 7 HD interchangeable gobos +open

The bidirectional variable rotation, Index functions, Bi-directional changeable speed shake effect, changeable speed and flow effect FEATURE

- Prism:1 rotating and indexable prism (3,8,16,24 facet option)

- Iris: Linear adjustable with macro

- Frost: 1 pcs Frost Filter, linear frost

- Focus: AUTO-FOCUS

- Zoom: 5°-45°linear adjustment

- Dimmer: 0-100% linear dimmer

- Strobe: Electronic strobe,0.3-20Times/SEC

CONTROL AND PROGRAMMING

- Standard mode: 25 channels

- Control mode: DMX512, 3-pin/5-pin DMX512; protocols RDM; wireless (option) and Art-Net (option)

- Manual programming: DMX and RDM data in/out

- Fan mode: NORMAL/PERFORMANCE/QUIET

OTHER FUNCTION

- 2.4inch color LCD screen

- High reliability touch button

- Support Multi-language

- Automatic monitoring light temperature, high temperature automatic protection

- Intelligent cooling system

- DMX512 Software update

- Display lamps use time

- 100% brightness without stroboscopic problem

- Internal rechargeable battery (3.7V rechargeable lithium-ion battery)

- Maintenance mode

- Intelligent control of wind speed

- Reverse display

- Control panel lock

POWER SUPPLY

- Input voltage:100V~240V AC 50/60Hz

- Rate power:500W@220V

- Power socket: power connector input and output

- DMX and RDM data in/out: Locking 3-pin & 5-pin XLR

HOUSING

- Environmentally friendly flame retardant materials

- High temperature resistant engineering plastics

- Device locking PAN and TILT mechanisms for transportation and maintenance.

- Intellectual property rights of appearance and structure design

- IP GRADE •IP:20

- Dimension: 337*337*568mm Net weight:15KG



GOBOS

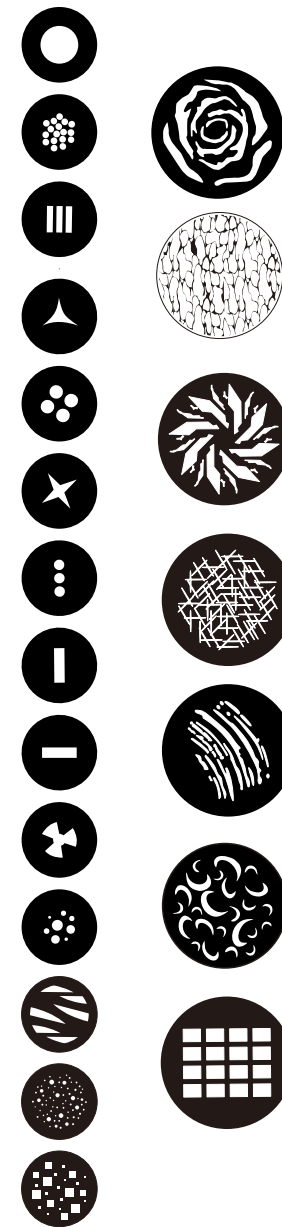

DMX CHANNEL

Channel NO.	Function	Description
Ch1	Pan	000 255
Ch2	Pan Fine	000 255
Ch3	Tilt	000 255
Ch4	Tilt Fine	000 255
Ch5	Color Wheel 1	000 255
Ch6	Cyan	000 255
Ch7	Magenta	000 255
Ch8	Yellow	000 255
Ch9	CTO	000 255
Ch10	Fixed Gobo wheel	000 255
Ch11	Rotating Gobo wheel	000 255
Ch12	Gobos Auto-Rotation	000 255
Ch13	Dimmer	000 255
Ch14	Strobe	000 255
Ch15	Dimmer mode	000 DELAY FAST 255
Ch16	Prism	000 255
Ch17	Prism Auto-Rotation	000 255
Ch18	Zoom	000 255
Ch19	Focus	000 255
Ch20	Auto Focus Distance	000 255
Ch21	Auto Focus Distance	000 255
Ch22	Iris	000 255
Ch23	Frost	000 255
Ch24	Scan speed	000 FAST SLOW 255
Ch25	Control	000 255

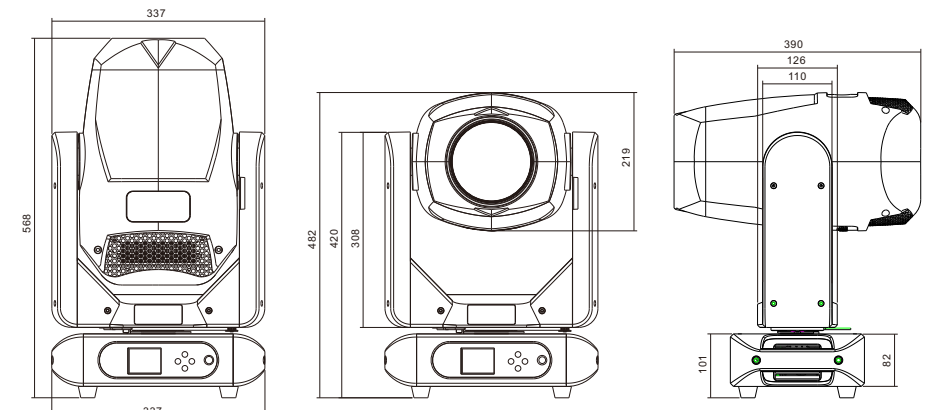

LUMEN

